

SECTION C CONTENTS

UNIBODY "SATURN[®]" BALL VALVES

DESCRIPTION	PAGE
9A-100 Series, Threaded Heavy Pattern Bronze	C-1
90-100 Series, Threaded Bronze (UL Listed)	C-2
91-100 Series, Threaded Bronze	C-3
92-100 Series, Threaded Carbon Steel	C-4
93-100 Series, Threaded Carbon Steel	C-5
96-100 Series, Threaded Stainless Steel	C-6

Saturn® 9A-100 Series

Bronze Uni-Body Heavy Pattern Saturn® Ball Valve

Threaded, 600 psig WOG, Cold Non-Shock. 150 psig Saturated Steam.

Federal Specification: WW-V-35C, Type: II, Composition: BZ, Style: 3.

MSS SP-110; Ball Valves Threaded, Socket-Welding, Solder Joint, Grooved and Flared Ends.

FEATURES

- Static grounding devices
- RPTFE seats and seals
- One piece bronze body
- Compact
- Blow-out-proof stem design
- Adjustable packing gland
- Chromium plated ball

STANDARD MATERIAL LIST

1. Lever and grip	Steel, zinc plated w/vinyl	7. Gland nut	B16
2. Stem packing	RPTFE	8. Stem	B16
3. Stem bearing	RPTFE	9. Lever nut (Screw 1/4" to 1/2")	Steel, zinc plated
4. Ball	B16, chrome plated	10. Ground spring	SS
5. Seat (2)	RPTFE	11. Body	B584-C84400
6. Retainer	B16		

VARIATIONS AVAILABLE:

9A-140 Series (316 SS Ball & Stem)

OPTIONS AVAILABLE:

(SUFFIX)	OPTION	SIZES
-03-	1-1/4" CS Stem Extension	1/4" to 2"
-04-	2-1/4" CS Stem Extension	1/4" to 2"
-05-	Plain Ball	1/4" to 2"
-07-	Steel Tee Handle	1/4" to 2"
-08-	90° Reversed Stem	3/4" to 2"
-10-	SS Lever & Nut	1/4" to 2"
-14-	Side Vented Ball (Uni-Directional)	1/4" to 2"
-15-	Wheel Handle, Steel	1/4" to 2"
-16-	Chain Lever - Vertical	1" to 2"
-17-	Rough Chrome Plated - Bronze Valves	1/4" to 2"
-20-	Slot Vented Ball (Bi-Directional) - Bronze Valves	1/4" to 2"
-24-	Graphite Packing	1/4" to 2"
-27-	SS Latch-Lock Lever & Nut	1/4" to 2"
-30-	Cam-Lock Handle & Grounded	1/4" to 2"
-32-	SS Tee Handle & Nut	1/4" to 2"
-40-	Cyl-Loc & Grounded	3/4" to 2"
-45-	Less Lever & Nut	1/4" to 2"
-46-	Latch Lock Lever - Lock in Closed Position Only	1/2" to 2"
-47-	SS Oval Latch-Lock Handle & Nut	1/4" to 1-1/4"
-48-	SS Oval Handle	1/4" to 2"
-49-	Assembled Dry	1/4" to 2"
-50-	2-1/4" CS Locking Stem Extension	3/4" to 2"
-57-	Oxygen Cleaned	1/4" to 2"
-58-	Chain Lever - Horizontal	1" to 2"
-60-	Grounded Ball & Stem	3/4" to 2"
-P01-	BSPP (Parallel) Thread Connection	1/4" to 2"
-T01-	BSPT (Tapered) Thread Connection	1/4" to 2"

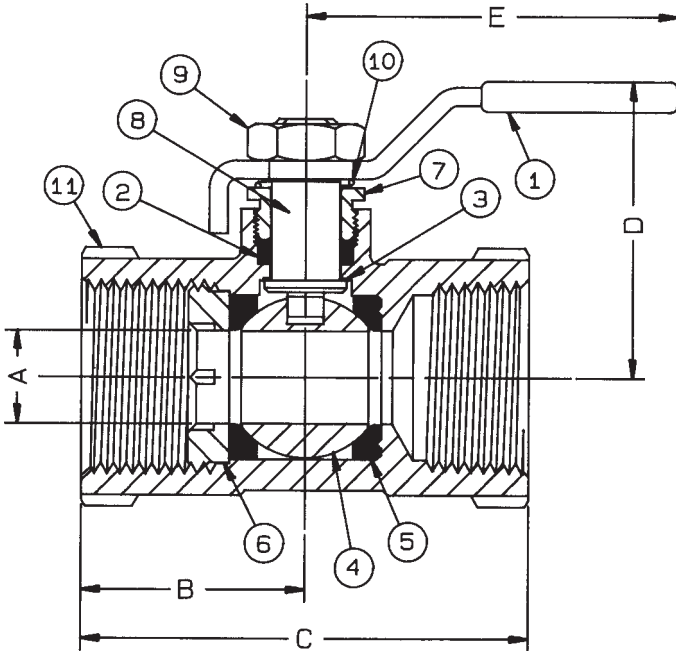

BRONZE UNI-BODY HEAVY PATTERN
SATURN® BALL VALVE

NUMBER	SIZE	A	B	C	D	E	Wt.
9A-101-01	1/4"	.37	1.34	2.59	1.64	3.87	.73
9A-102-01	3/8"	.37	1.34	2.59	1.64	3.87	.73
9A-103-01	1/2"	.37	1.34	2.59	1.64	3.87	.73
9A-104-01	3/4"	.50	1.44	2.84	1.78	3.87	1.10
9A-105-01	1"	.63	1.72	3.28	2.02	4.78	1.73
9A-106-01	1-1/4"	.82	1.94	3.84	2.27	4.78	2.92
9A-107-01	1-1/2"	1.00	2.06	4.00	2.70	5.43	3.96
9A-108-01	2"	1.25	2.29	4.56	2.92	5.43	5.97

**For Pressure/Temperature Ratings,
Refer to Page M-8, Graph No. 4**

Saturn® 90-100 Series

Bronze Uni-Body Saturn® Ball Valve

Threaded, 300 psig WOG, Cold Non-Shock. 150 psig Saturated Steam.

Federal Specification: WW-V-35C, Type: II, Composition: BZ, Style: 3.

MSS SP-110; Ball Valves Threaded, Socket-Welding, Solder Joint, Grooved and Flared Ends.

FEATURES

- UL Listed at 300 psig for fuel, inert gas and flammable liquids
- Valves with tee handles UL listed
- RPTFE seats and seals
- Blow-out-proof stem design
- Adjustable packing gland
- One piece bronze body
- Chromium plated ball
- Compact

UL LISTINGS



- Guide YRPV: Gas shutoff valve for use with natural and manufactured gases.
- Guide YQNZ: Compressed gas shutoff valve for use with air, inert gases, hydrogen, oxygen and common refrigerants except ammonia.
- Guide YRBX: Flammable liquid shutoff valve.

STANDARD MATERIAL LIST

1. Lever and grip	Steel, zinc plated w/vinyl	6. Retainer	B16
2. Stem packing	RPTFE	7. Gland nut	B16
3. Stem bearing	RPTFE	8. Stem	B16
4. Ball	B16, chrome plated	9. Lever nut (Screw 1/2")	Steel, zinc plated
5. Seat (2)	RPTFE	10. Body	B584-C84400

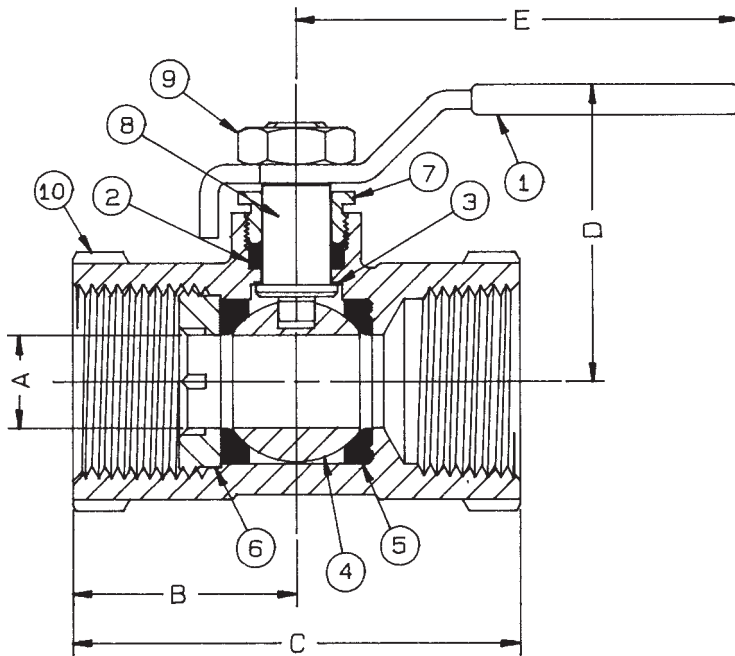

OPTIONS AVAILABLE:

(SUFFIX)	OPTION	SIZES
-05-	Plain Ball	1/2" to 2"
-07-	Steel Tee Handle	1/2" to 2"

BRONZE UNI-BODY SATURN® BALL VALVE

NUMBER	SIZE	A	B	C	D	E	Wt.
90-103-01	1/2"	.38	1.14	2.15	1.64	3.87	.53
90-104-01	3/4"	.50	1.36	2.61	1.78	3.87	.82
90-105-01	1"	.63	1.50	2.90	2.14	4.78	1.25
90-106-01	1-1/4"	.81	1.79	3.50	2.31	4.78	1.98
90-107-01	1-1/2"	1.00	1.96	3.79	2.87	5.43	2.99
90-108-01	2"	1.25	2.29	4.42	3.09	5.43	4.64

Saturn® 91-100 Series

Bronze Uni-Body Saturn® Ball Valve

Threaded, 400 psig WOG, Cold Non-Shock. 150 psig Saturated Steam.

Federal Specification: WW-V-35C, Type: II, Composition: BZ, Style: 3.

MSS SP-110; Ball Valves Threaded, Socket-Welding, Solder Joint, Grooved and Flared Ends.

FEATURES

- Compact
- RPTFE seats and seals
- One piece bronze body
- Blow-out-proof stem design
- Adjustable packing gland
- Chromium plated ball

STANDARD MATERIAL LIST

1. Lever and grip	Steel, zinc plated w/vinyl	6. Retainer	B16
2. Stem packing	RPTFE	7. Gland nut	B16
3. Stem bearing	RPTFE	8. Stem	B16
4. Ball	B16, chrome plated	9. Lever nut (Screw 1/4" to 1/2")	Steel, zinc plated
5. Seat (2)	RPTFE	10. Body	B584-C84400

VARIATIONS AVAILABLE:

91-120 Series (Adjustable Stop Lever)

91-140 Series (316 SS Ball & Stem)

91-150 Series (Original Balancing Stop)

OPTIONS AVAILABLE:

(SUFFIX)	OPTION	SIZES
-02-	Static Grounded	1/4" to 2"
-03-	1-1/4" CS Stem Extension	1/4" to 2"
-04-	2-1/4" CS Stem Extension	1/4" to 2"
-05-	Plain Ball	1/4" to 2"
-07-	Steel Tee Handle	1/4" to 2"
-08-	90° Reversed Stem	3/4" to 2"
-10-	SS Lever & Nut	1/4" to 2"
-14-	Side Vented Ball (Uni-Directional)	1/4" to 2"
-15-	Wheel Handle, Steel	1/4" to 2"
-16-	Chain Lever - Vertical	1" to 2"
-17-	Rough Chrome Plated - Bronze Valves	1/4" to 2"
-20-	Slot Vented Ball (Bi-Directional) - Bronze Valves	1/4" to 2"
-24-	Graphite Packing	1/4" to 2"
-27-	SS Latch-Lock Lever & Nut	1/4" to 2"
-30-	Cam-Lock Handle & Grounded	1/4" to 2"
-32-	SS Tee Handle & Nut	1/4" to 2"
-40-	Cyl-Loc & Grounded	3/4" to 2"
-45-	Less Lever & Nut	1/4" to 2"
-46-	Latch Lock Lever - Lock in Closed Position Only	1/2" to 2"
-47-	SS Oval Latch-Lock Handle & Nut	1/4" to 1-1/4"
-48-	SS Oval Handle	1/4" to 2"
-49-	Assembled Dry	1/4" to 2"
-50-	2-1/4" CS Locking Stem Extension	3/4" to 2"
-57-	Oxygen Cleaned	1/4" to 2"
-58-	Chain Lever - Horizontal	1" to 2"
-60-	Grounded Ball & Stem	3/4" to 2"
-P01-	BSPP (Parallel) Thread Connection	1/4" to 2"
-T01-	BSPT (Tapered) Thread Connection	1/4" to 2"

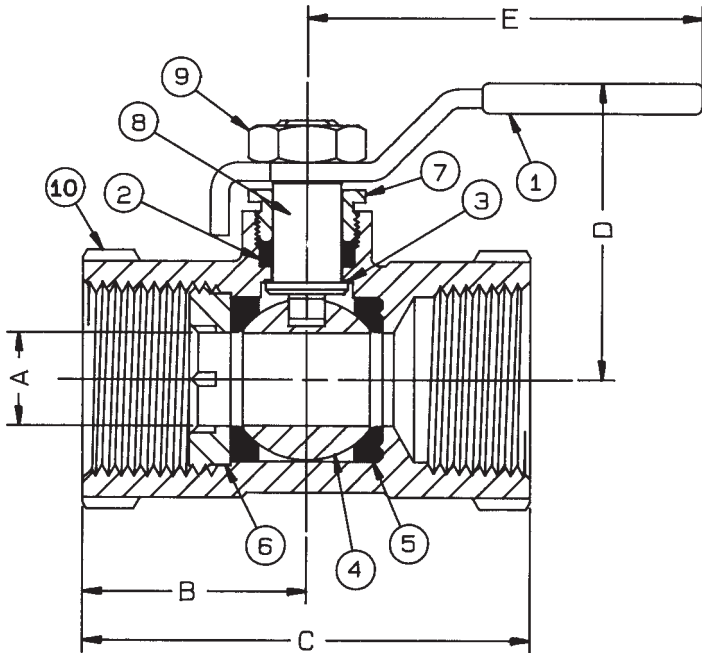

BRONZE UNI-BODY SATURN® BALL VALVE

NUMBER	SIZE	A	B	C	D	E	Wt.
91-101-01	1/4"	.38	1.14	2.15	1.71	3.87	.53
91-102-01	3/8"	.38	1.14	2.15	1.71	3.87	.53
91-103-01	1/2"	.38	1.14	2.15	1.71	3.87	.53
91-104-01	3/4"	.50	1.36	2.61	1.78	3.87	.82
91-105-01	1"	.63	1.50	2.90	2.02	4.78	1.25
91-106-01	1-1/4"	.81	1.79	3.50	2.18	4.78	1.98
91-107-01	1-1/2"	1.00	1.96	3.79	2.70	5.43	2.99
91-108-01	2"	1.25	2.29	4.42	2.92	5.43	4.64

**For Pressure/Temperature Ratings,
Refer to Page M-8, Graph No. 3**

Saturn® 92-100 Series

Carbon Steel Uni-Body Saturn® Ball Valve

Threaded, 1/4" to 1" 2000 psig WOG, 1-1/4" to 2" 1500 psig WOG, Cold Non-Shock. 150 psig Saturated Steam. Vacuum Service to 29 inches Hg.

Federal Specification: WW-V-35C, Type: II, Composition: CS, Style: 3.

MSS SP-110; Ball Valves Threaded, Socket-Welding, Solder Joint, Grooved and Flared Ends.

FEATURES

- (-24) Certified to API standard 607, 4th Edition, Class 600 burn
- Investment cast body
- RPTFE seats and seals
- Blow-out-proof stem design
- Nitride corrosion protection
- Adjustable packing gland
- Meets NACE MR-01-75 with SS trim
- Chromium plated ball
- Compact

STANDARD MATERIAL LIST

1. Lever and grip	Steel, zinc plated w/vinyl	6. Retainer	A108-CS
2. Stem packing	RPTFE	7. Gland nut	A108-CS
3. Stem bearing	RPTFE	8. Stem	A108-CS
4. Ball	A108-CS, chrome plated	9. Lever nut (Screw 1/4" to 1/2")	Steel, zinc plated
5. Seat (2)	RPTFE	10. Body	A216-WCB

VARIATIONS AVAILABLE:

92-140 Series (316 SS Ball & Stem)

OPTIONS AVAILABLE:

(SUFFIX) OPTION	SIZES	
-02-	Static Grounded	1/4" to 2"
-03-	1-1/4" CS Stem Extension	1/4" to 2"
-04-	2-1/4" CS Stem Extension	1/4" to 2"
-07-	Steel Tee Handle	1/4" to 2"
-08-	90° Reversed Stem	3/4" to 2"
-10-	SS Lever & Nut	1/4" to 2"
-14-	Side Vented Ball (Uni-Directional)	1/4" to 2"
-15-	Wheel Handle, Steel	1/4" to 2"
-16-	Chain Lever - Vertical	1" to 2"
-24-	Graphite Packing	1/4" to 2"
-27-	SS Latch-Lock Lever & Nut	1/4" to 2"
-30-	Cam-Lock Handle & Grounded	1/4" to 2"
-32-	SS Tee Handle & Nut	1/4" to 2"
-40-	Cyl-Loc & Grounded	3/4" to 2"
-45-	Less Lever & Nut	1/4" to 2"
-46-	Latch Lock Lever - Lock in Closed Position Only	1/2" to 2"
-47-	SS Oval Latch-Lock Handle & Nut	1/4" to 1-1/4"
-48-	SS Oval Handle	1/4" to 2"
-50-	2-1/4" CS Locking Stem Extension	3/4" to 2"
-58-	Chain Lever - Horizontal	1" to 2"
-60-	Grounded Ball & Stem	3/4" to 2"
-65-	Multifill Seats & Graphite Packing	1/4" to 2"
-P01-	BSP (Parallel) Thread Connection	1/4" to 2"
-T01-	BSPT (Tapered) Thread Connection	1/4" to 2"

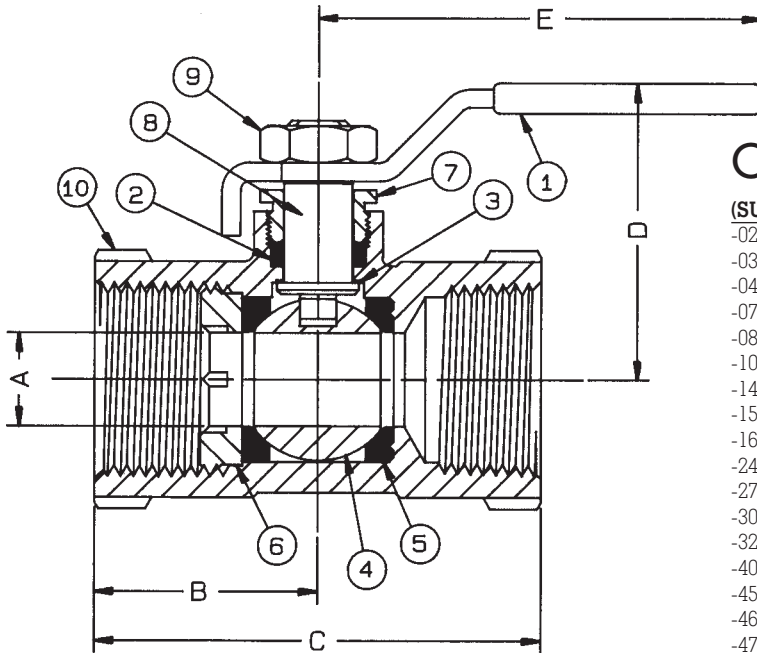

CARBON STEEL UNI-BODY
SATURN® BALL VALVE

NUMBER	SIZE	A	B	C	D	E	Wt.
92-101-01	1/4"	.38	1.14	2.21	1.64	3.87	.49
92-102-01	3/8"	.38	1.14	2.21	1.64	3.87	.49
92-103-01	1/2"	.38	1.14	2.21	1.64	3.87	.49
92-104-01	3/4"	.50	1.34	2.70	1.78	3.87	.76
92-105-01	1"	.63	1.51	3.03	2.00	4.78	1.21
92-106-01	1-1/4"	.81	1.79	3.62	2.18	4.78	1.95
92-107-01	1-1/2"	1.00	1.95	4.00	2.69	5.43	2.92
92-108-01	2"	1.25	2.28	4.73	2.91	5.43	4.73

**For Pressure/Temperature Ratings,
Refer to Page M-12, Graph No. 13
(1/4" to 1")
Refer to Page M-11, Graph No. 11
(1-1/4" to 2")**

Saturn® 93-100 Series

Carbon Steel Uni-Body Saturn® Ball Valve

Threaded, 1/4" to 1" 2000 psig WOG, 1-1/4" to 2" 1500 psig WOG, Cold Non-Shock. 150 psig Saturated Steam.
 Federal Specification: WW-V-35C, Type: II, Composition: CS, Style: 3.
 MSS SP-110; Ball Valves Threaded, Socket-Welding, Solder Joint, Grooved and Flared Ends.

FEATURES

- (-24) Certified to API standard 607, 4th Edition, Class 600 burn
- Uni-body barstock steel design
- RPTFE seats and seals
- Blow-out-proof stem design
- Adjustable packing gland
- Compact
- Chromium plated ball
- Nitride corrosion protection

STANDARD MATERIAL LIST

1. Lever and grip	Steel, zinc plated w/vinyl	6. Retainer	A108-CS
2. Stem packing	RPTFE	7. Gland nut	A108-CS
3. Stem bearing	RPTFE	8. Stem	A108-CS zinc plated
4. Ball	A108-CS chrome plated	9. Lever nut (Screw 1/4" to 1/2")	Steel, zinc plated
5. Seat (2)	RPTFE	10. Body	A108-CS

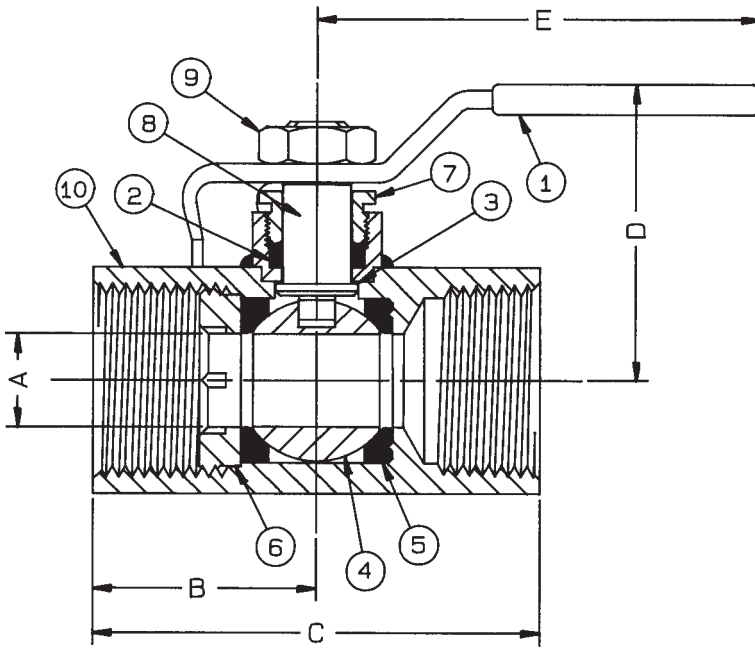

VARIATIONS AVAILABLE:

93-140 Series (316 SS Ball & Stem)

OPTIONS AVAILABLE:

(SUFFIX)	OPTION	SIZES
-02-	Static Grounded	1/4" to 2"
-03-	1-1/4" CS Stem Extension	1/4" to 2"
-04-	2-1/4" CS Stem Extension	1/4" to 2"
-07-	Steel Tee Handle	1/4" to 2"
-08-	90° Reversed Stem	3/4" to 2"
-10-	SS Lever & Nut	1/4" to 2"
-14-	Side Vented Ball (Uni-Directional)	1/4" to 2"
-15-	Wheel Handle, Steel	1/4" to 1-1/2"
-19-	Lock Plate (Suggest "92")	1/4" to 2"
-24-	Graphite Packing	1/4" to 2"
-45-	Less Lever & Nut	1/4" to 2"
-60-	Grounded Ball & Stem	3/4" to 2"
-P01-	BSPP (Parallel) Thread Connection	1/4" to 2"
-T01-	BSPT (Tapered) Thread Connection	1/4" to 2"

CARBON STEEL UNI-BODY SATURN® BALL VALVE

NUMBER	SIZE	A	B	C	D	E	Wt.
93-101-01	1/4"	.38	1.14	2.18	1.63	3.68	.56
93-102-01	3/8"	.38	1.14	2.18	1.63	3.68	.56
93-103-01	1/2"	.38	1.14	2.18	1.63	3.68	.56
93-104-01	3/4"	.50	1.35	2.66	1.75	3.68	.79
93-105-01	1"	.63	1.51	3.03	1.93	4.68	1.27
93-106-01	1-1/4"	.81	1.79	3.62	2.09	4.68	2.26
93-107-01	1-1/2"	1.00	1.96	4.00	2.71	5.50	3.57
93-108-01	2"	1.25	2.08	4.71	2.92	5.50	5.94

**For Pressure/Temperature Ratings,
 Refer to Page M-12, Graph No. 13
 (1/4" to 1")
 Refer to Page M-11, Graph No. 11
 (1-1/4" to 2")**

Saturn® 96-100 Series

Stainless Steel Uni-Body Saturn Ball Valve

Threaded, 1/4" to 1" 2000 psig WOG, 1-1/4" to 2" 1500 psig WOG, Cold Non-Shock. 150 psig Saturated Steam. Vacuum Service to 29 inches Hg.

Federal Specification: WW-V-35C, Type: II, Composition: SS, Style: 3.

MSS SP-110; Ball Valves Threaded, Socket-Welding, Solder Joint, Grooved and Flared Ends.

FEATURES

- (-24) Certified to API standard 607, 4th Edition, Class 600 burn
- Investment cast body
- RPTFE seats and seals
- Blow-out-proof stem design
- Adjustable packing gland
- Meets NACE MR-01-75
- Compact

STANDARD MATERIAL LIST

1. Lever and grip	304 SS w/vinyl	6. Retainer	A276-316
2. Stem packing	RPTFE	7. Gland nut	A276-316
3. Stem bearing	RPTFE	8. Stem	A276-316
4. Ball	A276-316	9. Lever nut (Screw 1/4" to 1/2")	18-8 SS
5. Seat (2)	RPTFE	10. Body	A351-CF8M

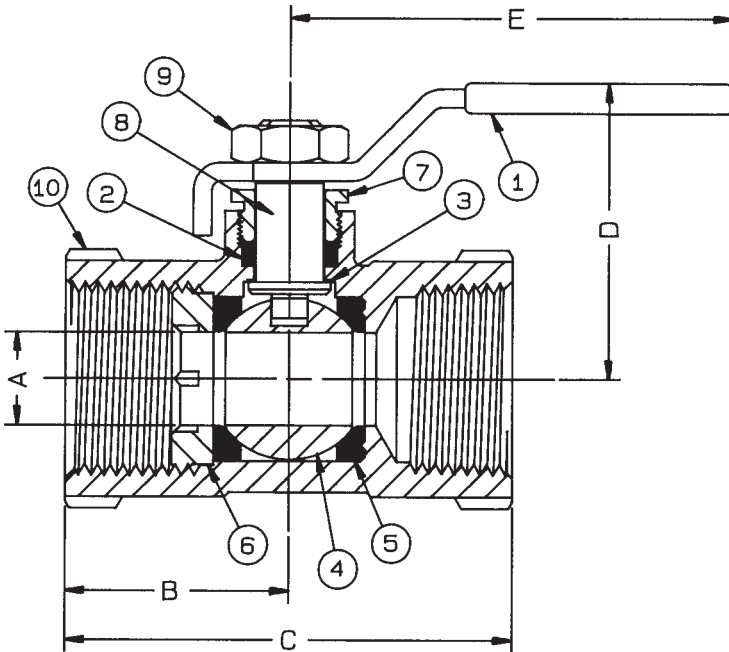

OPTIONS AVAILABLE:

(SUFFIX)	OPTION	SIZES
-02-	Stem Grounded	1/4" to 2"
-03-	1-1/4" CS Stem Extension	1/4" to 2"
-04-	2-1/4" CS Stem Extension	1/4" to 2"
-07-	Steel Tee Handle	1/4" to 2"
-08-	90° Reversed Stem	3/4" to 2"
-14-	Side Vented Ball (Uni-Directional)	1/4" to 2"
-15-	Wheel Handle, Steel	1/4" to 2"
-16-	Chain Lever - Vertical	1" to 2"
-24-	Graphite Packing	1/4" to 2"
-27-	SS Latch-Lock Lever & Nut	1/4" to 2"
-30-	Cam-Lock Handle & Grounded	1/4" to 2"
-32-	SS Tee Handle & Nut	1/4" to 2"
-40-	Cyl-Loc & Grounded	3/4" to 2"
-45-	Less Lever & Nut	1/4" to 2"
-47-	SS Oval Latch-Lock Handle & Nut	1/4" to 1-1/4"
-49-	Assembled Dry	1/4" to 2"
-57-	Oxygen Cleaned	1/4" to 2"
-58-	Chain Lever - Horizontal	1" to 2"
-60-	Grounded Ball & Stem	3/4" to 2"

AAR Approval No. E989054

STAINLESS STEEL UNI-BODY SATURN BALL VALVE

NUMBER	SIZE	A	B	C	D	E	Wt.
96-101-01	1/4"	.38	1.14	2.21	1.64	3.87	.49
96-102-01	3/8"	.38	1.14	2.21	1.64	3.87	.49
96-103-01	1/2"	.38	1.14	2.21	1.64	3.87	.49
96-104-01	3/4"	.50	1.33	2.70	1.78	3.87	.76
96-105-01	1"	.63	1.51	3.03	2.00	4.78	1.21
96-106-01	1-1/4"	.81	1.79	3.62	2.18	4.78	1.95
96-107-01	1-1/2"	1.00	1.95	4.00	2.66	5.43	2.92
96-108-01	2"	1.25	2.28	4.73	2.87	5.43	4.73

**For Pressure/Temperature Ratings,
Refer to Page M-12, Graph No. 14
(1/4" to 1")
Refer to Page M-11, Graph No. 12
(1-1/4" to 2")**