

DeVal[®] SERIES 44/45 & 47/48

Double Eccentric High Performance Butterfly Valves
Wafer and Lug

Sizes 2" - 36"

ASME Class 150 & Class 300



Leading the Industry with Innovation by Design

DelVal Flow Controls is pleased to offer top-of-the-line products in pipeline flow control. The DelVal® Series 44/45 and 47/48 High Performance Butterfly Valves have been developed with extensive application, design and manufacturing expertise. These products are produced by employing modern manufacturing practices under a robust quality assurance system. These practices ensure consistent product quality and dependable performance. The The DelVal® Series 44/45 and 47/48 High Performance Butterfly Valves have been designed to include state-of-the-art features that are described in this bulletin.

Features

Top Flange

The top flange is drilled as per EN ISO 5211 to accommodate direct mounting of a wide range of actuators.

Body

One-piece wafer body style or full lug style for dead end service. Both body styles offer bidirectional sealing as standard in conformance with full ASME class 150 and class 300 rating.

Wedge Pin

Pins are offset from the center of the stem which places them in compression rather than shear thus eliminating potential for failure. The pins are precision fit and wedge type which provide positive mechanical attachment of disc to stem.

Disc Stop

The disc stop is designed to prevent disc from rotating in wrong direction and to minimize possible seat damage.

Seat Retainer

Retains seat in the body and is supplied in the same material as the body.

Stem Seal

Gland flange assembly is "live loaded" with Belleville Springs. This ensures continuous compression of packing and sealing contact at the stem and body. Rocker shaped gland bridge compensates for uneven adjustment of gland bolts.

Blow-out Proof Stem

Retainer circlip provides blow -out proof stem.

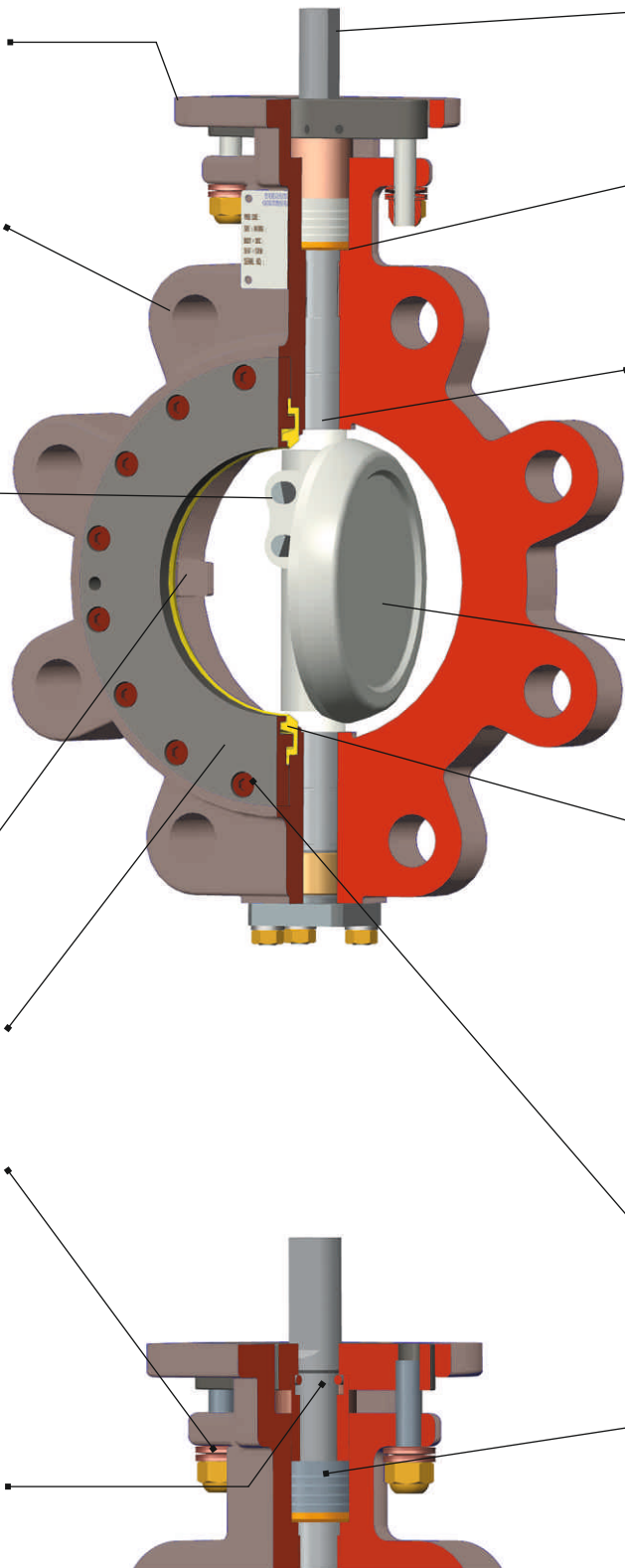

Stem

The high-strength, stainless steel one-piece stem provides maximum strength for high torque applications.

Extended Neck

Extended neck allows for 2" of pipeline insulation and easy access to stem packing adjustment and actuator mounting.

Bearings

The drive and non-drive end stem "Bear-X" bearings are made out of an engineered high compressive strength composite polymer material having excellent thermal, chemical and wear resistance.

Disc

The disc has been engineered to maximize flow and minimize resistance to provide a high flow coefficient (Cv).

Seat

The unique seat design utilizes a flexible lip seal concept. When the disc closes, this action causes a slight deflection in the seat, energizing the seat. During this energized position, the seat has a stored energy force constantly pushing against the disc. In addition to this "energized" force, when pressure is on the insert side, the pressure pushes under the lip which further amplifies the sealing force between the disc and the seat.

Bi-Directional Dead End Service

All lug valves are suitable for dead-end service to full ASME pressure rating, bi-directionally.

Adjustable Stem Packing

The stem packing system features a pull down gland with easy access to the adjusting hex head nuts without removal of the actuator.

Features and Selection

Double Offset Disc Design

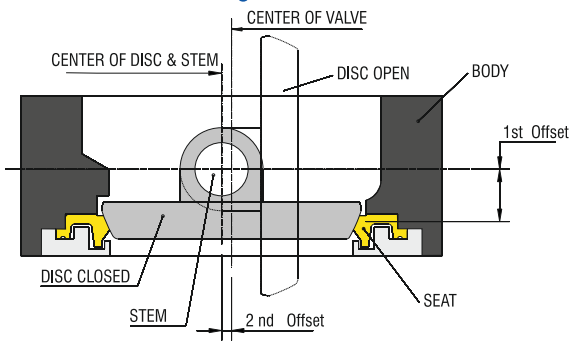

The offset disc produces a cam-like action, pulling the disc from the seat. This action reduces seat wear and eliminates seat deformation when the disc is in the open position. The disc does not contact the seat when the valve is in the open condition; therefore, seat service life is extended and torques are reduced. As the valve closes, the cam-like action converts the rotary motion of the disc to a linear type motion effectively pushing the disc onto the seat.

Seat Designs

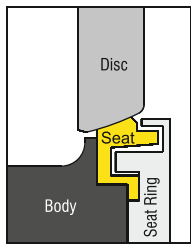

Soft Seat

Soft Seat : Flexible lip seat design retains its original shape and maintains a seal against the disc regardless of the flow direction.

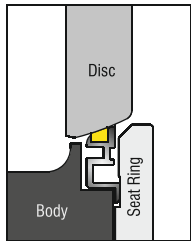

Fire Safe Seat

Fire Safe Seat : During and after fire, when the resilient material has been partially or completely destroyed, the metal seat ring provides a positive seal by remaining in constant contact with the disc in either direction of media flow.

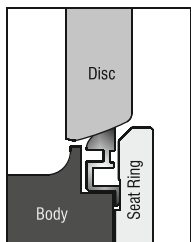

Metal Seat

Metal Seat : Flexible metal seat offers a very high sealing capability with low leakage rates. The mechanical properties and the shape of the metal seat allow it to flex and maintain constant positive sealing against the disc.

Seat Pressure / Temperature

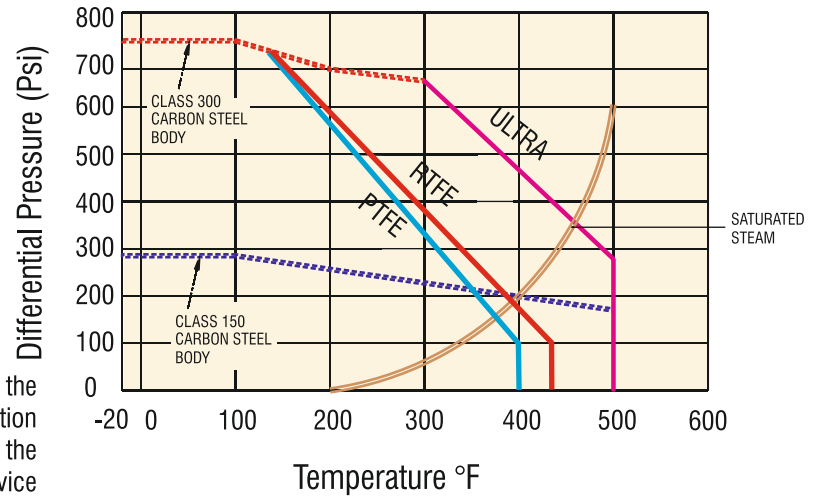

ULTRA Seat

An engineered fluorocarbon polymer that is rated for 500 °F at 285 psi. Excellent for handling aggressive fluids at high pressures, Ultra is recommended for extended service in hostile environments involving chemical, thermal, and mechanical stress. Ultra has excellent thermal stability and is ideal for steam, hot gases, and a variety of process chemicals where service can also be subject to pressure cycling.

Special Applications

Vacuum

Standard valves are rated for tight shut-off of vacuum to 2×10^{-2} torr.

Oxygen

Valves for critical gaseous oxygen service are specially prepared, cleaned, inspected, assembled and tested to ensure removal of all burrs, sharp edges, dirt, hydrocarbon oil or grease and other contaminants.

NACE Service

Valves conform to NACE MR 0175 are available. These valves are well suited for oil and gas industry applications requiring resistant materials to sulfide stress cracking.

Steam

Valves are available for saturated steam at 200 Psi rating with Ultra seat for series 44/45 and 450 Psi for series 47/48.

SPECIFICATION AND CODES

Design : API 609, ASME B16.34, BS EN 593, BS EN12516

Face to Face: API 609, ASME B16.10, ISO 5752, BS EN 558

Testing: API 598, BS EN 12266-1, ANSI-FCI 70-2 Class VI, ISO 5208, ANSI-FCI 70-2 Class IV for Metal Seat

Flange Accommodation : ASME B16 5, Optional-BS EN 1092

Fire Safe : API 607

Compliance With: Pressure Equipment Directive PED/97/23/EC

Body Style: Wafer and Lug

Pressure Rating : Class 150, Class 300

Temperature Range : -20°F to 500°F (soft seat)
-20°F to 1000°F (metal seat)

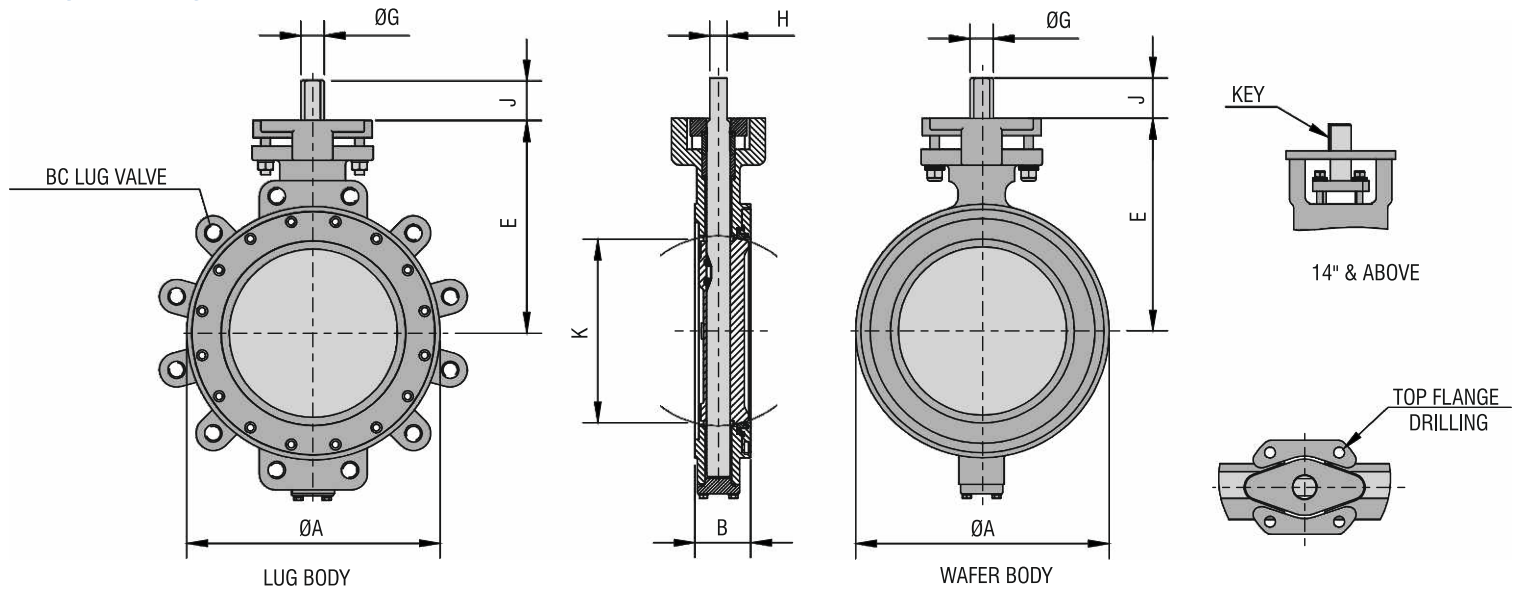

ASME CLASS 150 (Series 44/45)

DIMENSIONS (Inch)

Valve Size	DN	ØA	B*	E	Top Flange Drilling			ØG	H	J	Key Size	K	Lug Bolting Data					Apx. Weights In Lbs	
					BC	No. of holes	Hole Dia.						BC	No. of holes	Tapping UNC/UN-2B	Wafer (Series 44)	Lug (Series 45)		
2	50	3.81	1.69	4.92	2.76	4	0.39	0.55	0.39	1.25	-	1.57	4.75	4	5/8-11	6.6	8.8		
2 1/2	65	4.13	1.81	5.75	2.76	4	0.39	0.63	0.43	1.25	-	2	5.50	4	5/8-11	8.8	10.8		
3	80	5.47	1.88	5.90	2.76	4	0.39	0.63	0.43	1.25	-	2.7	6.00	4	5/8-11	10.8	13.8		
4	100	6.69	2.12	6.77	2.76	4	0.39	0.63	0.43	1.25	-	3.56	7.50	8	5/8-11	15.8	26.4		
5	125	6.77	2.25	7.40	2.76/4.01	4	0.39/0.47	0.75	0.51	1.25	-	4.36	8.50	8	3/4-10	19.6	29.5		
6	150	8.50	2.25	8.23	2.76/4.01	4	0.39/0.47	0.75	0.51	1.25	-	5.46	9.50	8	3/4-10	24.2	31.24		
8	200	10.59	2.50	9.45	4.92	4	0.55	0.87	0.63	1.25	-	7.21	11.75	8	3/4-10	25.6	47.0		
10	250	12.76	2.81	10.70	4.92	4	0.55	1.18	0.87	2.00	-	9.16	14.25	12	7/8-9	61.0	89.9		
12	300	15	3.19	12.20	4.92	4	0.55	1.38	0.94	2.00	-	10.93	17.00	12	7/8-9	111.1	126.1		
14	350	16.25	3.62	15.94	4.92/5.51	4	0.55/0.71	1.57	-	2.00	0.47 x 0.31	12.09	18.75	12	1-8	136.7	182.3		
16	400	18.50	4.00	17.95	5.51/6.5	4	0.71/0.87	1.97	-	2.50	0.47 x 0.39	13.94	21.25	16	1-8	205.0	248.0		
18	450	21.02	4.50	19.33	5.51/6.5	4	0.71/0.87	2.16	-	2.50	0.63 x 0.39	15.94	22.75	16	1 1/8-8	233.2	306.4		
20	500	23.00	5.00	21.1	6.50	4	0.83	2.36	-	4.00	0.71 x 0.43	18.35	25.00	20	1 1/8-8	252.0	412.9		
24	600	27.36	6.06	24.96	6.5/10	8	0.87/0.71	2.75	-	4.00	0.78 x 0.47	20.58	29.50	20	1 1/4-8	507.1	701.5		
30	750	33.74	7.52	29.7	10	8	0.71	3.5	-	4.00	0.88 x 0.62	28	36	28	1 1/4-8	990	1584		
36	900	40.23	8	33.85	11.73	8	0.82	4	-	5.25	1.00 x 0.75	34	42.5	32	1 1/2-8	1661	2648		

* Face to Face dimension "B" generally conforming to MSS SP Table 1 / API 606 Category B / BS EN 558-1 / ISO 5752 / ASME B 16.10
All bolt holes 1 1/8" and larger have an 8-UN thread series as per MSS SP 68 & API 609.

Cv VALUES - VALVE SIZING COEFFICIENT

Disc Position (deg)	Valve Size															
	2"	2.5"	3"	4"	5"	6"	8"	10"	12"	14"	16"	18"	20"	24"	30"	36"
10	3	5	10	24	39	63	132	198	306	360	474	602	840	1210	1890	3342
20	5	8	17	40	65	105	220	326	510	600	790	1004	1400	2016	3150	5570
30	8	12	25	60	98	158	330	498	765	900	1185	1506	2100	3024	4725	8355
40	11	18	37	90	146	236	495	752	1148	1350	1778	2259	3150	4536	7088	12533
50	16	25	53	128	208	336	704	1056	1632	1920	2528	3213	4480	6451	10080	17824
60	24	37	78	188	306	494	1034	1552	2397	2820	3713	4719	6580	9475	14805	26179
70	35	55	116	280	455	735	1540	2310	3570	4200	5530	7028	9800	14112	22050	38990
80	45	70	149	360	585	945	1980	2970	4590	5400	7110	9036	12600	18144	28350	50130
90	50	78	165	400	650	1050	2200	3300	5100	6000	7900	10040	14000	20160	31500	55700

Rated Cv = The volume of water in Usgpm that will pass through a given valve at a pressure drop of 1 Psi

DeVal reserves rights to change the content without notice.

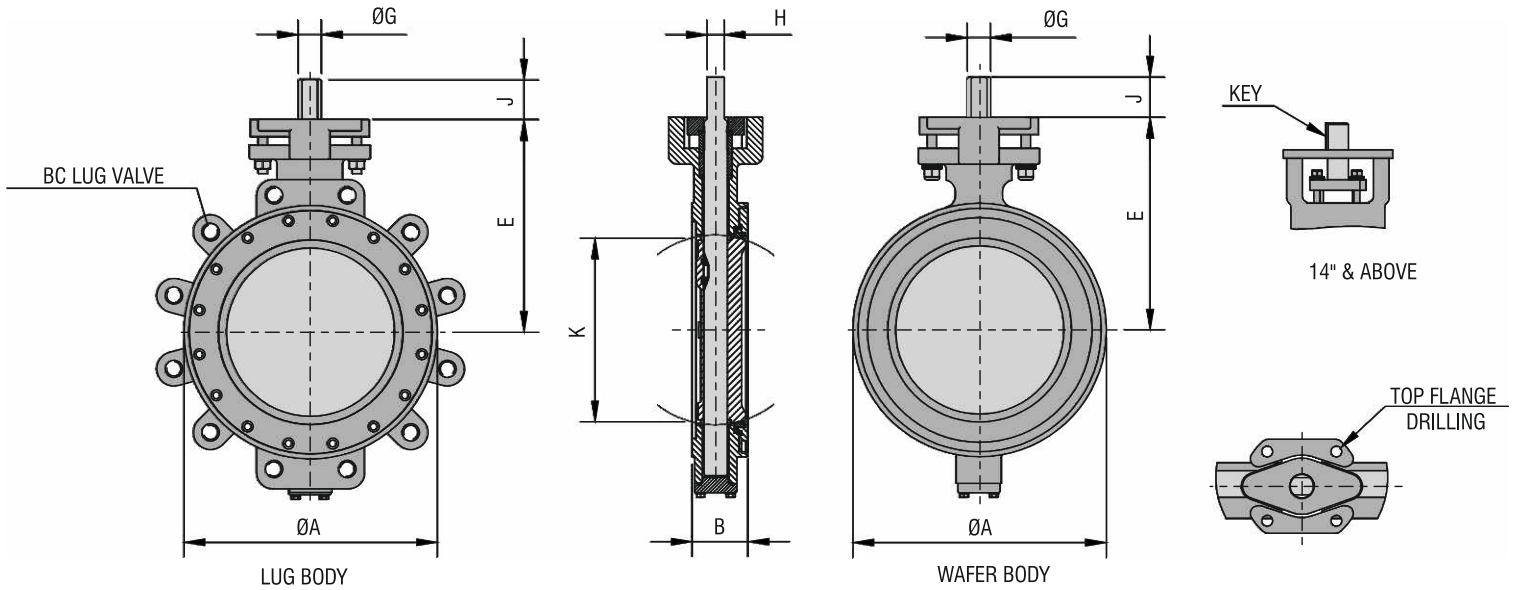

ASME CLASS 300 (Series 47/48)

DIMENSIONS (Inch)

Valve Size	DN	ØA	B*	E	Top Flange Drilling			ØG	H	J	Key Size	K	Lug Bolting Data			Apx. Weights In Lbs	
					BC	No. of holes	Hole Dia.						BC	No. of holes	Tapping UNC/UN-2B	Wafer (Series 47)	Lug (Series 48)
2	50	3.81	1.69	4.92	2.76	4	0.39	0.55	0.39	1.25	-	1.57	4.75	4	5/8-11	7.7	8.8
2 1/2	65	4.13	1.81	5.75	2.76	4	0.39	0.63	0.43	1.25	-	2.0	5.88	8	3/4-10	8.8	15.0
3	80	5.20	1.88	6.22	2.76	4	0.39	0.63	0.43	1.25	-	2.7	6.63	8	3/4-10	12.8	18.1
4	100	6.77	2.12	6.77	2.76	4	0.39	0.63	0.43	1.25	-	3.56	7.88	8	3/4-10	17.2	24.9
5	125	7.32	2.31	7.87	2.76/4.01	4	0.39/0.47	0.75	0.51	1.25	-	4.36	9.25	8	3/4-10	20.2	31.3
6	150	8.50	2.31	8.66	4.92	4	0.55	0.87	0.63	1.25	-	5.46	10.63	12	3/4-10	31.3	68.8
8	200	10.63	2.88	11.22	4.92	4	0.55	1.18	0.87	1.25	-	7.1	13.00	12	7/8-9	53.1	79.1
10	250	12.83	3.25	11.80	4.92	4	0.55	1.38	0.94	2.00	-	9.0	15.25	16	1-8	88.6	116.4
12	300	15.00	3.62	13.43	5.51/6.50	4	0.71/0.87	1.57	1.14	2.00	-	10.7	17.75	16	1 1/8-8	151.7	201.1
14	350	16.26	4.62	18.00	5.51/6.50	4	0.71/0.87	2.17	-	2.50	0.63 x 0.39	12.1	20.25	20	1 1/8-8	285.9	326.3
16	400	18.50	5.25	19.70	6.50	4	0.83	2.17	-	2.50	0.63 x 0.39	13.7	22.50	20	1 1/4-8	337.5	403.0
18	450	21.46	5.88	21.65	10.00	8	0.71	2.75	-	4.00	0.78 x 0.47	15.6	24.75	24	1 1/4-8	391.3	515.4
20	500	23.00	6.25	23.62	10.00	8	0.71	3.50	-	4.00	0.88 x 0.62	17.2	27.00	24	1 1/4-8	508.8	737.4
24	600	27.24	7.12	27.56	11.73	8	0.82	4.00	-	5.25	1.00 x 0.75	20.6	32.00	24	1 1/2-8	735.0	1015.9

* Face to Face dimension "B", generally conforming to MSS SP 68 TABLE 1 / API 609 Category B / ASME B 16.10
All bolt holes 1 1/8" and larger have an 8-UN thread series as per MSS SP 68 & API 609.

Cv VALUES - VALVE SIZING COEFFICIENT

Disc Position (degrees)	Valve Size														
	2"	2.5"	3"	4"	5"	6"	8"	10"	12"	14"	16"	18"	20"	24"	
10	3	5	10	24	39	63	108	190	285	284	416	556	677	1110	
20	5	8	17	40	65	105	180	316	475	473	693	927	1128	1850	
30	8	12	25	60	98	158	270	474	713	710	1040	1391	1692	2775	
40	11	18	37	90	146	236	405	711	1069	1064	1559	2086	2538	4163	
50	16	25	53	128	208	336	576	1012	1520	1514	2218	2966	3610	5920	
60	24	37	78	188	306	494	846	1485	2233	2223	3257	4357	5302	8695	
70	35	55	116	280	455	735	1260	2212	3325	3311	4851	6489	7896	12950	
80	45	70	149	360	585	945	1620	2844	4275	4257	6237	8343	10152	16650	
90	50	78	165	400	650	1050	1800	3160	4750	4730	6930	9270	11280	18500	

Rated Cv = The volume of water in Usgpm that will pass through a given valve at a pressure drop of 1 Psi
DeVal reserves rights to change the content without notice.

Torque

Maximum Seating and Unseating Torques for ASME Class 150 Soft Seat Design

Maximum Torques Lb - Inch						
Valve Size		Differential Pressure (Psi)				
Inch	DN	50	100	150	230	285
2	50	212	230	239	248	257
2.5	65	243	249	260	270	284
3	80	284	295	304	327	358
4	100	384	409	434	472	601
5	125	518	571	616	690	734
6	150	778	842	920	1025	1094
8	200	1313	1431	1548	1765	1893
10	250	1705	1941	2158	2509	2785
12	300	2080	2526	2977	3659	4117
14	350	3442	4262	5125	6505	7398
16	400	4391	5473	6588	8285	9523
18	450	5715	7152	8546	10835	12471
20	500	7624	9623	11467	14720	16791
24	600	11548	14587	17773	22639	26178
30	750	21196	25771	30346	37665	42701
36	900	34205	42143	50082	62782	71516

Fire Safe Seat Design

Maximum Torques Lb - Inch						
Valve Size		Differential Pressure (Psi)				
Inch	DN	50	100	150	230	285
2	50	460	478	496	522	540
2.5	65	482	501	515	541	555
3	80	607	630	646	677	706
4	100	751	796	835	895	948
5	125	849	917	999	1127	1209
6	150	1424	1548	1681	1881	1998
8	200	2340	2590	2787	3145	3425
10	250	3523	3916	4368	5058	5561
12	300	5248	6035	6796	7931	8826
14	350	6229	7140	8009	9554	10534
16	400	7188	8350	9683	11620	13051
18	450	9148	11408	13900	17523	20223
20	500	12944	16447	19817	25626	29348
24	600	20391	24109	28074	34394	38251

Metal Seat Design

Maximum Torques Lb - Inch						
Valve Size		Differential Pressure (Psi)				
Inch	DN	50	100	150	230	285
2	50	513	531	557	584	620
2.5	65	603	616	649	676	700
3	80	747	788	808	833	875
4	100	946	1003	1036	1110	1190
5	125	1053	1137	1269	1407	1516
6	150	1780	1936	2085	2342	2477
8	200	2949	3263	3484	3948	4266
10	250	4333	4903	5525	6261	7032
12	300	6613	7484	8529	9894	11099
14	350	7787	9032	10017	11919	13141
16	400	8985	10479	12079	14641	16272
18	450	11527	14488	17202	22176	25037
20	500	16050	20395	24682	32192	36717
24	600	25488	30378	35022	43151	47680

Maximum Seating and Unseating Torques for ASME Class 300 Soft Seat Design

Maximum Torques Lb - Inch						
Valve Size		Differential Pressure (Psi)				
Inch	DN	150	285	360	585	740
2	50	239	257	283	354	372
2.5	65	260	284	302	373	420
3	80	304	358	389	476	534
4	100	434	601	656	839	956
5	125	781	982	1087	1427	1649
6	150	1062	1363	1551	2075	2436
8	200	2015	2658	3015	4066	4825
10	250	2992	4081	4686	6468	7752
12	300	4186	5653	6456	8866	10526
14	350	6407	9359	11130	15992	19419
16	400	7776	11238	13205	19301	23407
18	450	10049	14617	17126	24652	29838
20	500	13280	19389	23053	33283	40615
24	600	18112	26366	30846	45141	54495

Fire Safe Seat Design

Maximum Torques Lb - Inch						
Valve Size		Differential Pressure (Psi)				
Inch	DN	150	285	360	585	740
2	50	495	540	558	593	620
2.5	65	515	555	587	624	653
3	80	646	706	727	771	812
4	100	835	948	1071	1278	1433
5	125	1093	1284	1389	1713	1920
6	150	1817	2182	2398	3009	3439
8	200	2980	3646	4011	5099	5832
10	250	4479	5396	5917	7420	8527
12	300	7302	9537	10639	14300	16816
14	350	8197	10679	12052	16168	19000
16	400	9934	13406	15312	21296	25401
18	450	15287	22589	26735	38803	47426
20	500	21287	32025	37587	55613	67082
24	600	34193	50493	59313	85917	104127

Metal Seat Design

Maximum Torques Lb - Inch						
Valve Size		Differential Pressure (Psi)				
Inch	DN	150	285	360	585	740
2	50	557	620	663	699	735
2.5	65	649	700	734	786	810
3	80	808	875	905	956	1015
4	100	1036	1190	1326	1582	1787
5	125	1377	1590	1733	2133	2382
6	150	2253	2731	3006	3773	4323
8	200	3734	4520	5068	6380	7244
10	250	5552	6725	7331	9197	10622
12	300	9201	11802	13371	17803	21188
14	350	10145	13349	15075	20380	23770
16	400	12324	16724	19137	26630	31753
18	450	19109	28469	33146	48096	58836
20	500	26830	39922	47359	69850	83685
24	600	42587	63621	74195	107276	130200

Note :- Above torque values are indicative and defined for flow in preferred direction i.e. seat retainer upstream.
 For torque values for flow in non-preferred direction i.e. seat retainer downstream, multiply the above values by 1.25
 DeVal reserves rights to change the content without notice.

Exploded View

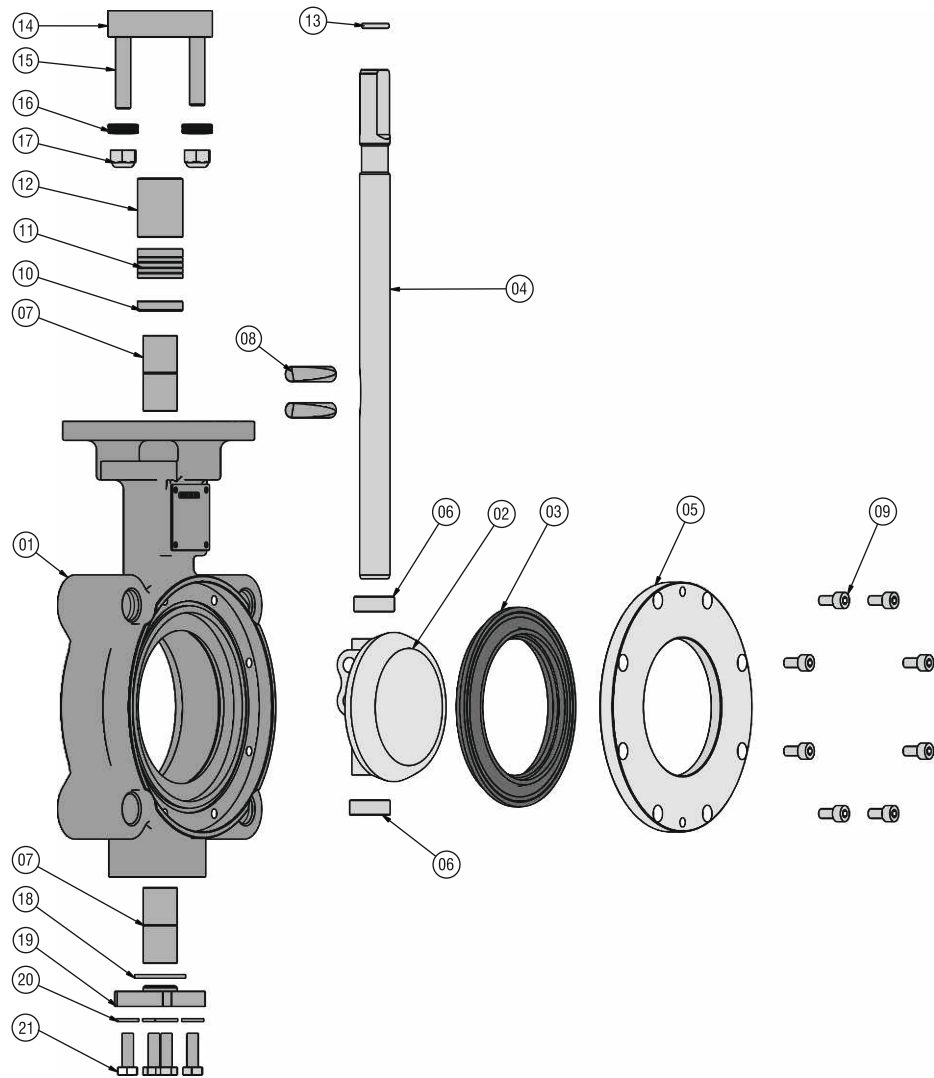

Item	Component	Carbon Steel	Stainless Steel
1	Body	A216 WCB	A351 CF8/CF8M
2	Disc	A351 CF8/CF8M	
3*	Seat	ULTRA/ RPTFE (2" to 24") PTFE (14" to 24") FIRESAFE-SS316+ULTRA (2" to 24") METAL-SS316/INCONEL 625 (2" to 24")	
4	Stem	A564 17-4 PH / A479 TYPE 316 / A479 XM -19	
5	Seat Retainer	Carbon Steel	SS TYPE 304 /SS TYPE 316
6	Disc Spacer	SS TYPE 316	
7*	Bearing	Bear - X/ SS 316+Kevlar® / HT 316	
8	Wedge Pin	17-4 PH	
9	Retainer Screw	A4-70(SS316)	
10	Packing Support	SS TYPE 316	
11*	Stem Packing	PTFE (CHEVRON)/ GRAPHITE	

Item	Component	Carbon Steel	Stainless Steel
12	Gland	SS TYPE 316	
13*	Snap Ring	STAINLESS STEEL	
14	Gland Flange	Carbon Steel	SS TYPE 304
15	Gland Flange Stud	GR. B8	
16	Belleville Spring	Stainless Steel	
17	Nyloc Nut	A2-70(SS304)	
18*	Gasket	PTFE/GRAPHITE	
19	Bottom Flange	Carbon Steel	SS TYPE 316
20	Washer	SS TYPE 304	
21	Hex Hd Bolt	GR. B8	

The materials shown are representative, all other materials are available on request e.g. LCB, Duplex SS, Super Duplex
*Recommended Spares.

